

# Technical Data sheet

## bravo™ Manual lever chain hoist

ref. : **T 2430 GB**  
rev. n° : **01**  
date : **11/15**  
page : **1/1**

### Characteristics :

- compact design unit and light-weight,
- coating : paint,
- load chain coated,
- hooks rotating 360° labeled with hoist W.L.L. fitted with safety latches removable,
- standard lifting height: 1.5m. Other possible lifting heights: see table below,
- unit designed and built to withstand dynamic testing at 1.1 W.L.L.\* and static testing at 1.5 x W.L.L.\* ,
- unit designed to ensure a minimum mechanical strength of 4 x W.L.L.\*.
- unit complies with directive 2006/42/CE requirements.

\* : Working Load Limit.

### Technical specifications :

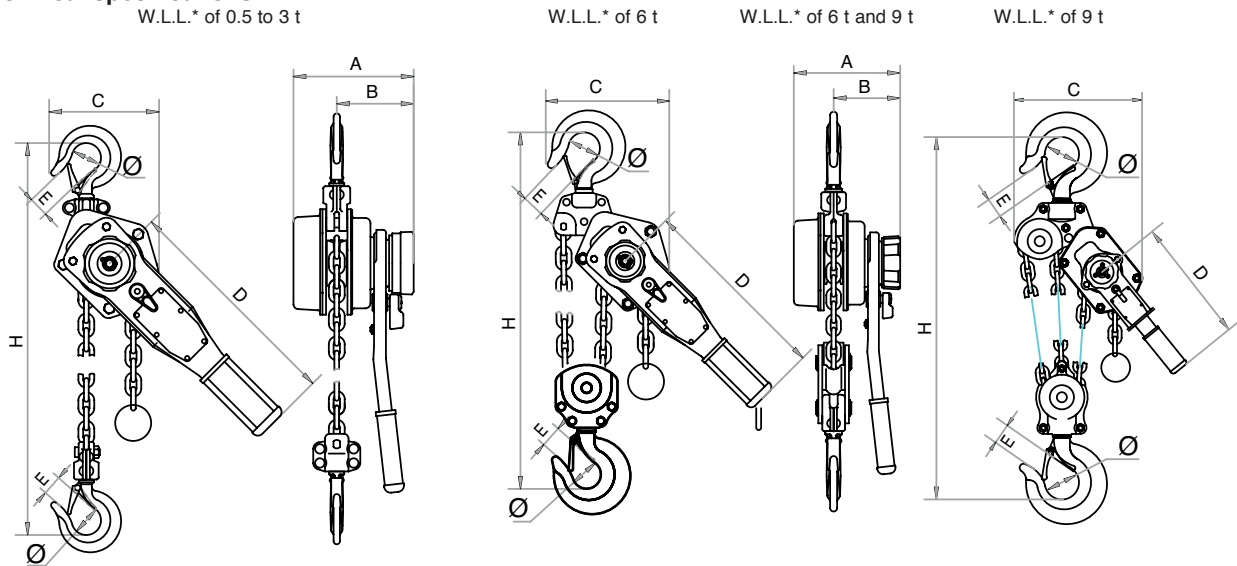

W.L.L.* (t)	0.5	0.75	1	1.5	3	6	9
Standard lifting height** (m)	1.5						
Minimum distance between hook H (mm)	260	325	325	380	480	620	700
Maximum force on handle at W.L.L.* (N)	340	140	190	220	320	340	360
Number of strands	1					2	3
Chain dimensions Ø x P (see fig. 1)	5 x 15	6 x 18	6x18	8 x 24	10 x 30		
Dimensions (mm)	A	105	148	148	172	200	200
	B	78	90	90	98	115	115
	C	80	136	136	160	180	235
	D	300	280	280	410	410	410
	E	30	30	30	36	40	50
	Ø	35	37	37	45	50	64
Net weight (kg)	4	7	7	11	21	31	44
Additional weight by lifting m (kg)	0.54	0.8	0.8	1.4	2.2	4.4	6.6

\*\* : other travel distances possible : 3 m ; 4.5 m ; 6 m  
Optionally, the bravo™ hoists of W.L.L. 0.75t / 1t / 1.5t / 3t / 6t / 9t can equipped with a dynamic load limiter adjusted between 1.1 and 1.9 x W.L.L.\*

